



## BASIC DEVICES FOR MOLECULAR ELECTRONICS

<sup>1</sup>Shubhashree Damle,<sup>2</sup>Mayur Parate,<sup>3</sup>Nitin Gawai,<sup>4</sup>Bhalchandra Chikate<sup>1</sup>Student of Electronics And Telecommunication, Jawaharlal Darda Institute Of Engineering And Technology, Yavatmal, Maharashtra, India  
[damle.shubhashree@gmail.com](mailto:damle.shubhashree@gmail.com)<sup>2</sup>Faculty of Electronics And Telecommunication, Jawaharlal Darda Institute Of Engineering And Technology, Yavatmal, Maharashtra, India  
[mrparate1787@gmail.com](mailto:mrparate1787@gmail.com)<sup>3</sup>Faculty of Electronics And Telecommunication, Jawaharlal Darda Institute Of Engineering And Technology, Yavatmal, Maharashtra, India  
[ningawai@rediffmail.com](mailto:ningawai@rediffmail.com)<sup>4</sup>Faculty of Electronics And Telecommunication, Jawaharlal Darda Institute Of Engineering And Technology, Yavatmal, Maharashtra, India  
[babluchikate@yahoo.com](mailto:babluchikate@yahoo.com)**Abstract**

Due to high power consumption and difficulties with minimizing the CMOS transistor size, molecular electronics has been introduced as an emerging technology. Further, there have been noticeable advances in fabrication of molecular wires and switches and also molecular diodes can be used for designing different logic circuits. It is easier to build electronic circuits using molecules since they are small and their properties can be tuned. Molecular electronics has some advantages over other technologies for implementing logic circuits. The size of molecules is at least 1nm and at most 100nm. This leads to less area and power dissipation. Considering this novel technology, molecules are used as the active components of the circuit, for transporting electric charge. In this paper, a half adder cell based on molecular electronics is presented. The area occupied by this kind of half adder would be much times smaller than the conventional designs and it can be used as the building block of more complex molecular arithmetic circuits.

**Index Terms:** Basic Model Design, Conductors, Semiconductor diode, Basic AND, XOR gate, Half Adder, Molecular half adder

**1. INTRODUCTION**

The ability to use single molecules functioning as electronic devices has motivated researchers to minimize the size of the circuits in semiconductor industry. There have been advances previously such as microelectronics that has minimized the sizes through laws of physics. However, because of quantum mechanics and limitations of fabrication methods, further improvements could not be achieved. Packaging millions of silicon devices in a chip will lead to huge power consumption and expense. Molecular electronics gives us flexibility in design such that we don't have it in traditional inorganic electronic materials. New molecular-electronic systems, architectures and analytical tools have been explored by chemists, physicists and engineers. Molecular components such as switches, rectifiers, transistors

and memories are now arising. In fact, molecular electronics systems are composed of molecules with specific functions.

Molecular electronics has some advantages over other technologies for implementing logic circuits. The size of molecules is at least 1 nm and at most 100nm. This leads to less area and power dissipation. Switching can be done on the single-molecule scale. Many molecules have different geometric structures allowing distinct optical and electrical features. In addition, tools have been developed for molecular synthesis. There are also some disadvantages like instability at high temperature, reproducibility and the effective control of single-molecule transport.

There are two main molecular electronic structures utilized for logic design namely polyphenylene-based chains and carbon nanotubes. However, it is much easier to design more complex logic structures using polyphenylene.

Polyphenylene chain has been used as resonant tunneling diodes, resistors and wires. Carbon nanotubes have been used in implementing logic and arithmetic circuits such as full adders, FPGA switches, multiple-valued logic circuits.

## 2. BASIC MODEL DESIGN

Designing molecules and molecular systems are like programming electronic devices. Molecular programming model gives a designing of molecular systems with information processing capability using molecular programming. It aims at establishing systematic design principles for molecules and molecular systems with information processing capabilities and developing methods to ease their design and construction.

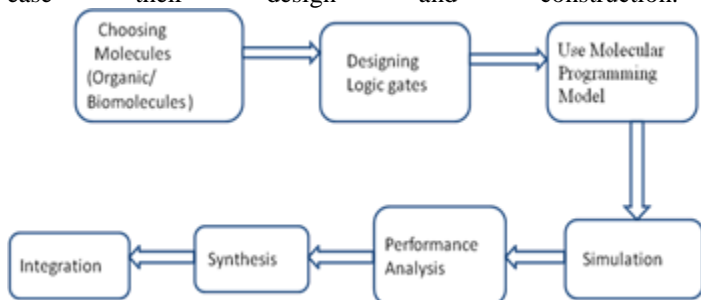

Fig-2.1: Basic structure of Molecular Electronic System

Molecular programming model gives a designing of molecular systems with information processing capability using molecular programming. It aims at establishing systematic design principles for molecules and molecular systems with information processing capabilities and developing methods to ease their design and construction. Methods in molecular programming are roughly classified in to those for designing molecules and those designing molecular reactions.

### 2.1. Base Architecture for Molecular Programming

The architecture of the processes involved in giving a model to molecular designing of molecular device shown in fig2.2. The process starts with choosing the organic molecules to design molecular diode and extend to molecular logic gates (We have taken only AND). The proper simulation of molecules can be found out with choosing the donor, acceptor and insulator and their arrangement according to the residue molecule attached on it. The molecular properties get studied taking Donor-Insulator-Acceptor as single molecule with benzene as nuclei. The molecular orbital properties also studied with many molecular orbital combinations with donor, acceptor and insulator as separate entity flowing along with benzene. The overlapping properties of highest orbitals found out once the multi-nuclei molecules get arranged with each other arbitrarily in the same surface dominated by benzene. The evaluation of the electronic properties has done with orbital motion and energy studies have done by taking computational chemistry and molecular physics rules.

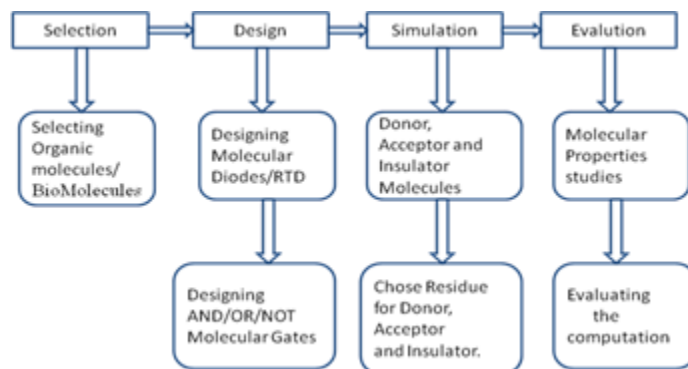

Fig-2.2: Architecture of Molecular Simulation and Programming

Molecular systems, or systems based on organic molecules, possess interesting and useful electronic properties. Going through various family of organic molecules and determine the electrical and insulating properties of molecules is the primary need.

## 3. POLYPHENYLENE-BASED COMPONENTS

In this we use polyphenylene-based components. To gain a special functionality in logic design, firstly molecular structures as switches are build and then combined them into a complex circuit.

### 3.1 Conductors

Polyphenylene-based conductors are composed of benzene rings with one or two hydrogen atoms eliminated. Benzene (C<sub>6</sub>H<sub>6</sub>) and its equivalent notations are illustrated in Fig-3.1.

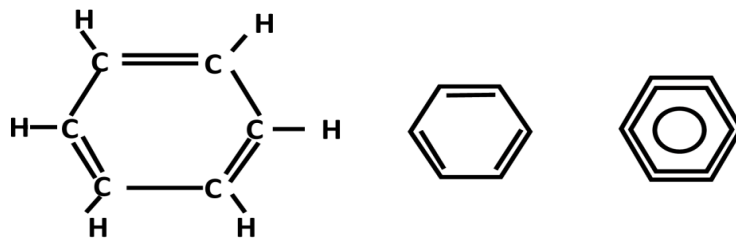

Fig-3.1: Benzene ring

In Fig-3.2, we see the phenyl and phenylene rings followed by a polyphenylene chain. We get polyphenylene by binding phenylene rings to each other on both sides and terminating the result with phenyl groups. They can be made in different shapes and lengths. Benzene and polyphenylene molecules are called aromatic.

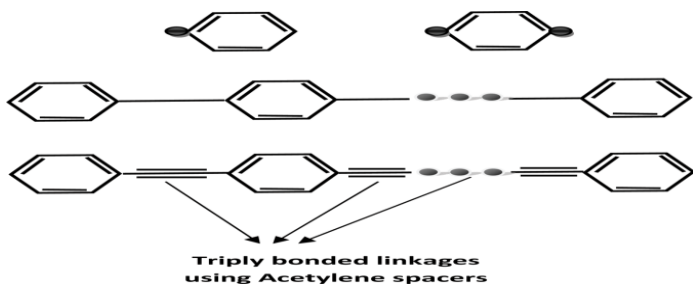

Fig-3.2: Polyphenylene chain

### 3.2 Diodes

Two types of diodes have been implemented via molecular electronics: rectifying diode, and resonant tunneling diode (RTD).

#### 3.2.1 Rectifying Diode

A rectifying diode is an electrical element which passes electric current through one direction. The direction which passes the current can be understood via the graphical symbol. It has a lot of applications in designing electric circuits. The first research about molecular electronics was based on rectifying diodes in 1974. The attempts showed that the lowest unoccupied molecular orbital (LUMO) and the highest occupied molecular orbital (HOMO) can be aligned in such a way that conduction is only feasible in one direction. In this way, constructing molecular diode is possible. Fig-3.3 shows the structure of a rectifying diode. It consists of two sections S1, and S2 which is separated by an insulating group R.

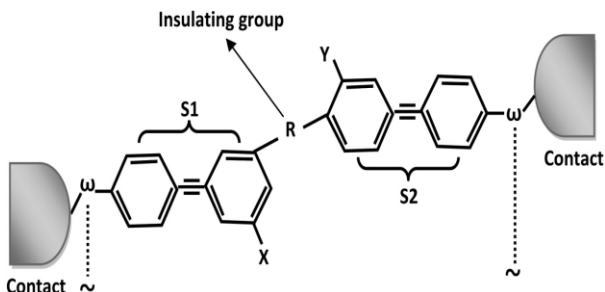

Fig-3.3: Structure of a molecular diode

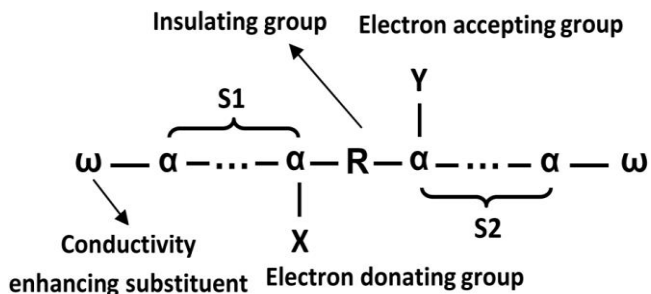

Fig-3.4: Schematic representation of a molecular diode

[http:// www.ijfeat.org](http://www.ijfeat.org)

#### 3.2.2 Molecular Resonant Tunneling Diode

The RTD has been intensely researched in last three decades as a promising nanoelectronic device for both analog and digital application. RTDs have been fabricated using the semiconductor heterostructure epitaxial techniques to realize the peak current-voltage characteristics that are typical of tunnel diodes but without the associated problems of large junction capacitance. The structure of a molecular resonance tunneling diode based on a molecular conducting wire backbone is shown in Fig- 3.5. In this structure, two aliphatic methylene groups (CH<sub>2</sub>) are inserted on both sides of the benzene ring. Since aliphatic groups act as insulators, they create potential barriers to the flow of electrons in the molecular conducting wire. The only way for the current to flow in the presence of an applied voltage is when the electrons are forced to pass through the benzene ring whose width is only about 0.5 nm.

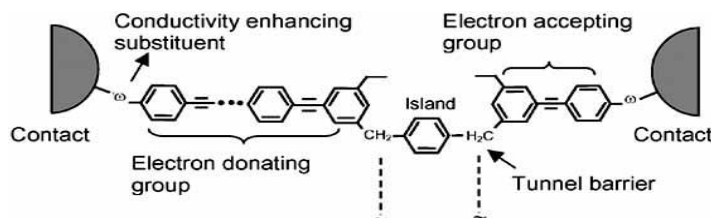

Fig-3.5: Structure of molecular resonant tunneling diode

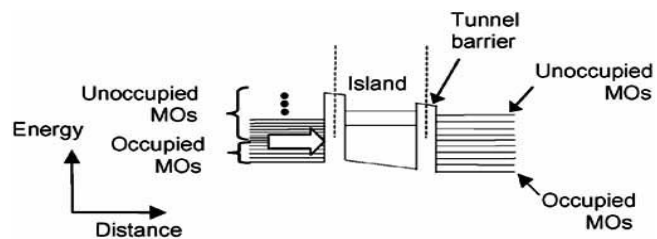

Fig-3.6: Band diagram of the molecular RTD showing the 'OFF' state

## 4. MONOMOLECULAR DIGITAL LOGIC STRUCTURES

The basic logic gates like AND, OR, and XOR have been designed based on molecular diodes and other reconfigurable architectures. Different other basic gates such as NOT, NAND and NOR can be constructed with the aid of aforementioned gates. The first two gates use two rectifying diodes and the last one uses one additional resonant tunneling diode.

There are also some programming techniques for designing logic circuits based on RTD. The final destination of molecular programming is to provide information processing systems at molecular levels.

#### 4.1 Realization of Diode Logic Molecular AND Gate

The circuit representation of a diode logic AND gate is shown in (Fig-4.1) and the schematic representation of the diode logic molecular AND gate is shown in (Fig- 4.2). The

schematic of the exemplary poly-phenylene diode logic molecular AND gate is shown in (Fig- 4.3)

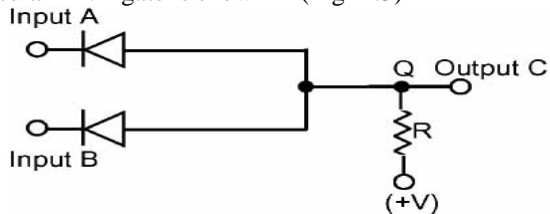

Fig-4.1. Circuit diagram of the diode logic AND gate

The molecular AND gate consists of two inputs A and B and one output C connected to the respective contacts. This structure exhibits the classical semiconductor AND gate behaviour.

As shown in (Fig-4.1), the single molecule AND gate consists of (i) two conducting wires each having a donating section (with at least one electron donating group) as well as an accepting section (with at least one electron accepting group), and (ii) a respective insulating group R inserted between the accepting and donating sections.

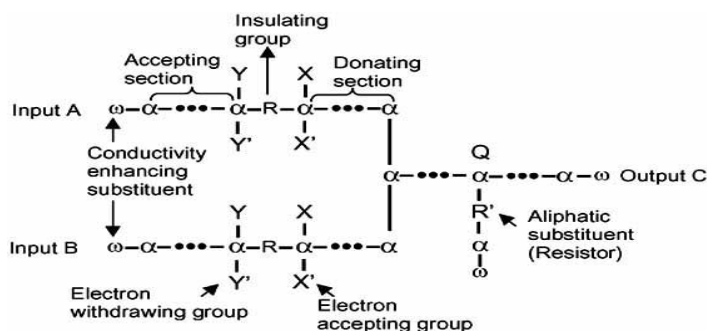

Fig-4.2: Schematic representation of the diode logic molecular AND gate

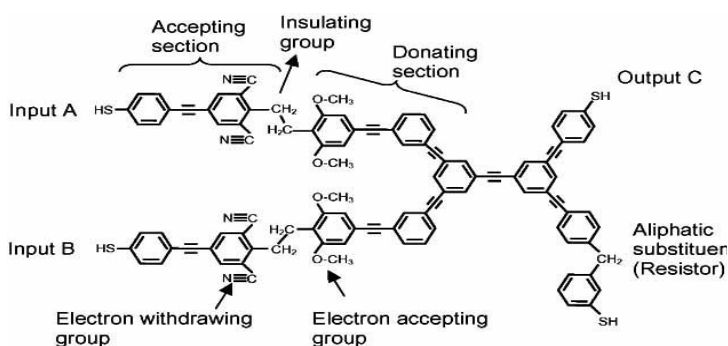

Fig-4.3: Schematic of the exemplary poly-phenylene diode logic molecular AND gate

What is important about the above molecular AND gate is that it is extremely small measuring only 3 nm × 4 nm in area which is at least a million times smaller than the gates realized using conventional semiconductor technology.

## 4.2 Realization of Molecular XOR Gate Using a Molecular RTD

The schematic gate of the XOR gate is shown in Fig-4.4 and the exemplary molecular implementation of the XOR gate is shown in Fig-4.5. The molecular XOR gate consists of two diode-embedded molecular wires with an effective resistance  $R_0$  and their acceptor sections are chemically bonded to a common connecting node. The resistance  $R_G$  is made of an insulating chain. One end of  $R_G$  is connected to the negative potential and the other end is connected to point Q through a conducting wire. The molecular RTD is connected between the connecting node and point Q. The molecular diode has the current-voltage behavior as shown in Fig-4.6. Another polyphenylene conducting wire is connected between point Q and the output node C of the XOR gate of which the input nodes are A and B.

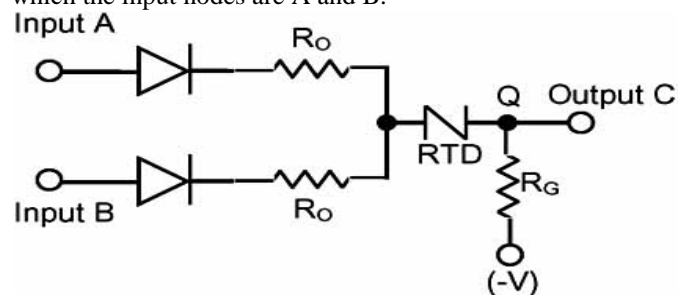

Fig-4.4: Circuit diagram of the diode logic XOR gate using the molecular RTD

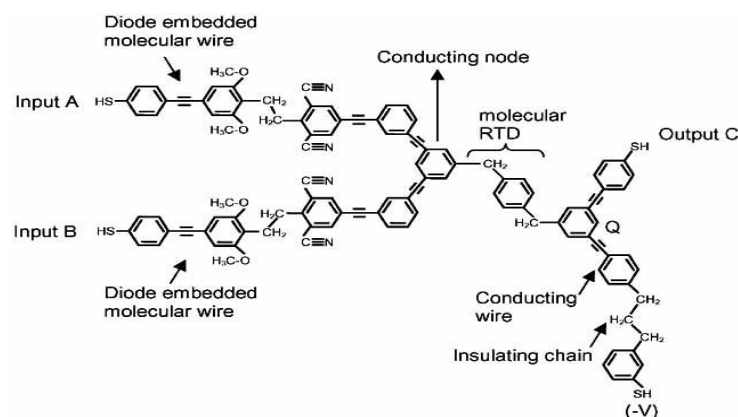

Fig-4.5: Schematic representation of the diode logic molecular XOR gate using the molecular RTD

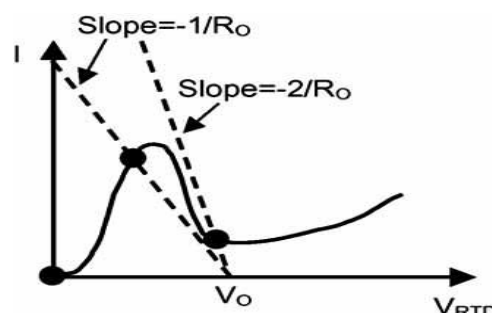
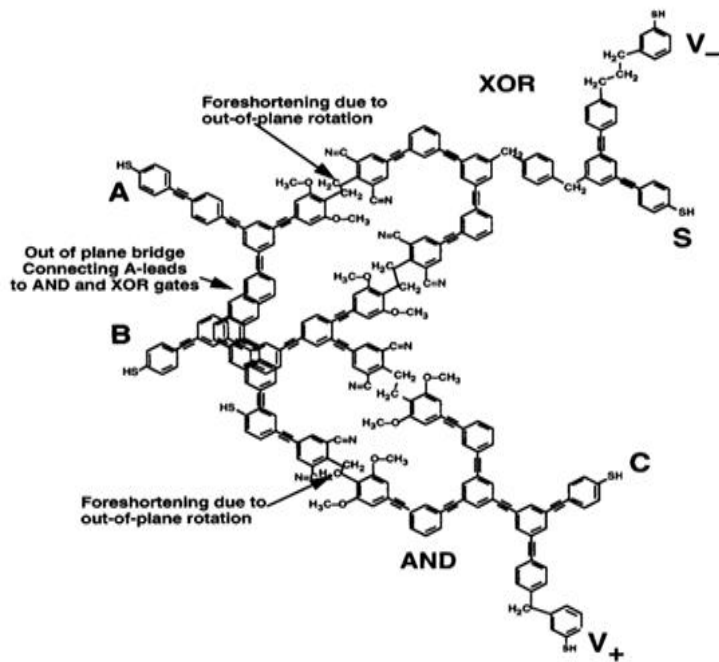

Fig-4.6: Current-voltage characteristics of an RTD incorporated into the molecular XOR gate



### 5. MOLECULAR ELECTRONIC HALF ADDER

By combining the structures for the molecular AND gate and the molecular XOR gate given in Figs. 12 and 14, respectively, one may build a structure for a molecular electronic half adder, as shown in Fig-5.2. The well-known combinational logic circuit for a binary half adder is shown in Fig-5.1(a). The novel design for the molecular structure corresponding to that combinational logic diagram is displayed in Fig- 5.2(c). It arises from the substitution of the molecular structures proposed above for the component AND and XOR gates. The structure in Fig-5.2 is a molecule that should add two binary numbers electronically when the currents and voltages representing the addends are passed through it. In Fig- 5.2, A and B represent the 1-bit binary inputs to the adder, while S and C represent the 1-bit outputs, the sum and the carry bits, respectively. Currents introduced into the half adder structure via either of the input leads or on the left are divided to pass into both of the function's component molecular logic gates. As is suggested by Fig-5.1(b), the logic operation performed by the XOR gate forms the sum of two bits and outputs it at lead S, with the "excluded" XOR operation on a 1 input to the adder at A and 1 input at B representing the arithmetic binary sum. Simultaneously, the AND gate component of the half adder can form the carry bit from the same two input 1 bits, and it provides this result as an output at C. The Tour-type molecular wire that constitutes the adder's input lead branches in the plane of the molecule immediately to the right of to connect to the lower input lead of the XOR gate and the upper input lead of the AND gate. The input signal current through lead B would be split accordingly between the two component gates. The other input signal, which passes through the molecular half adder's lead A, similarly would be split between both the AND gate and the XOR gate. The Tour wire that begins on the left at A in Fig-5.2 connects directly to the upper lead of the XOR gate in the plane of the molecule. However, the out-of-plane, linked-ring, arc-like aromatic molecular structure is then necessary to pass over the in-plane molecular wire for lead B and then connect lead A to the lower lead of the AND gate. This out-of-plane molecular connector corresponds to the arc in the schematic in Fig-5.1(a), which also is used to pass over input lead B.

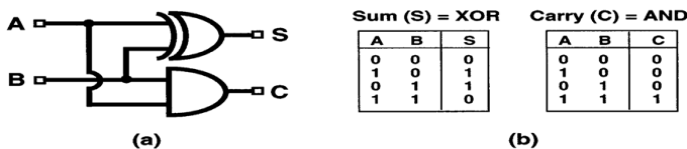

**Fig-5.2: Molecular Electronic Half Adder CONCLUSION**

In this paper, fundamental issues about molecular electronics were introduced first and two kinds of molecular structures were described. The complete set of single molecule structures (diodes, RTDs, conductors and insulators and the logic gates based on these) can in fact be used to build more complex Boolean functions. Using the above approach, it is also possible to build an electronic switching device with power gain by adding a gate structure to a molecular diode forming a single molecule which functions as a three terminal transistor similar to the a conventional silicon field effect transistor. As a result, it is now possible to realize in a large single molecule to provide molecular inverters with power gain, a possibility with immense applications in digital circuit design. Likewise, great contributions can be done using hybridization techniques.

### REFERENCES

- [1]. Mehdi Ghasemi, Mohammad Hossein Moaiyeri, and Keivan Navi,(2011)"A new full adder cell for molecular electronics", International Journal of VLSI design & Communication Systems (VLSICS) Vol.2, No.4.
- [2]. J.Ellenbogen and J.Love, (2000) "Architectures for molecular electronic computers: 1. Logic structures and an adder designed from molecular electronic diodes," Proceedings of the IEEE, Vol.88, No. 3, pp. 386-426.
- [3]. M.R.Pradhan, and E.G.Rajan, (2010) "A system engineering approach to molecular electronics, International Journal of Computer Applications, Vol. 3, No. 8, pp. 14-23.



**Fig-5.1: Binary Half Adder**

- [4]. M.J.Kumar, (2007) "Molecular diodes and applications," Recent Patents on Nanotechnology, Vol. 1, No. 1, pp. 51-57.
- [5]. M. A. Reed, "Molecular-scale electronics," Proc. IEEE, vol. 87, pp.652–658, Apr. 1999.
- [6]. R. C. Jaeger, Microelectronic Circuit Design. NewYork: McGraw-Hill, 1997.
- [7]. P. Manzumder, S. Kulkarni, M. Bhattacharya, p. S. Jian, and G. I. Haddad, (1998) "Digital circuit applications of resonant tunneling devices," Proceeding of the IEEE, Vol. 86, No. 4, pp. 664-686.
- [8]. S. C. Goldstein, and D. Rosewater, (2002) "Digital logic using molecular electronics," International Solid-State Circuits Conference, Digest of Technical Papers, Vol. 1, pp. 160-451.
  
- [9]. M. R. Pradhan, and E.G. Rajan, (2010) "Molecular programming pseudo-code representation to molecular electronics," Journal of Computing, Vol. 2, No. 5, pp. 93-100.
- [10]. J. Nero, F. Souza, and R. Capaz, (2010) "Molecular electronics devices: short review," JournalComputational and Theoretical Nanoscience, Vol. 7, No. 3, pp.503-516.
- [11]. Guo XF, Zhang DQ, Zhang GX, Zhu DB. Monomolecular logic:"Half-adder" based on multistate/multifunctional photochromicspiropyrans. J Phys Chem B 2004; 11942-11945.